

# LYRIC™ CLASSICAL ACOUSTIC MICROPHONE

## WARNING!

Lyric must be installed by an authorized L.R. Baggs dealer to qualify for warranty coverage. Technical assistance will not be provided for home or hobbyist installations.

## INSTALLATION INSTRUCTIONS

### STEP 1. STRAPJACK / PREAMP INSTALLATION

#### Drilling the strapjack hole

Drill a clean ½" hole in the tail-block for the strapjack. Remove wood shavings & dust from inside the guitar.

#### Installing the strapjack

Remove the strap ring, retaining nut and one washer from the end of the jack. There should still be one star locking washer, one flat washer and a nut remaining on the jack. Bring the jack down through the soundhole into the body and insert it into the pre-drilled hole in the tail block. Using the internal nut (be sure to include the flat and star washers), set the proper depth that will allow the entire smaller threaded section to protrude from the instrument (**see figure 1**).

With the jack in place, lay the remaining washer over the threads and attach the external retaining nut until it's tight. Finish by attaching the strap ring (it should cover the retaining nut and washer)

### STEP 2. INSTALLING THE MICROPHONE

Lyric's microphone is designed to attach to the underside of the guitar's top with the included peel-and-stick VHB adhesive. **CAUTION:** Use only the provided adhesive pads for this installation as they are sized and tuned specifically for this microphone. **DO NOT USE SUPER GLUE!** An additional set of pads is provided.

**Microphone Placement:** It is important to understand that each guitar is different. The recommended mic placement is only a suggested starting position. You may need to experiment with location for best results. For guitars without bridge plates, attach the mic between the braces just in front of the saddle as shown in (**figure 2**). For guitars with bridge plates, attach the mic between the braces just in front of the bridge plate as shown in (**figure 3**). Reach inside the hole and clean around under the top to be sure the guitar is free from oil, dust and other debris. Remove the adhesive backing from the bottom surface and attach the mic. Press firmly along the top surface of the mic, especially on the ends to secure it. Apply counter pressure from the outside of the guitar as you press on the mic to avoid cracking the top. Gently wiggle the mic back and forth as you press to help it set. Lastly, secure the wire with a wire clip near the mic (**see figures 2 & 3**).

If you need to remove the mic, place as many finger as you can on its side and gently pull down and towards the brace – Do not yank or tug. Hold this position until the VHB releases from the top.

### STEP 3. FINISHING THE INSTALLATION

#### Battery placement

Place the battery bag in an easily accessible spot with the velcro pad included. Be sure to clean the area thoroughly before installation.

#### Volume control placement

Find a suitable location near the top inner edge of the soundhole for the volume pot. Clean the area, peel off the backing from the adhesive and put the remote into place. Secure all wires with the supplied wire clips and re-string the guitar.

#### Adjusting the Mic Presence Control

Setting this control correctly is vital for optimizing Lyric's sound and performance (**see figure 4 for location**). Play through a P.A. or good acoustic amplifier when making your adjustments with the supplied tool. This control is highly responsive, so make subtle adjustments.

Your amplified tone should be well balanced and true to the acoustic sound and feel of the guitar. If it lacks clarity and top-end, increase the mic's presence by turning the control clockwise. Back it off slightly if you experience excessive handling noise and/or brightness.

Fig. 1

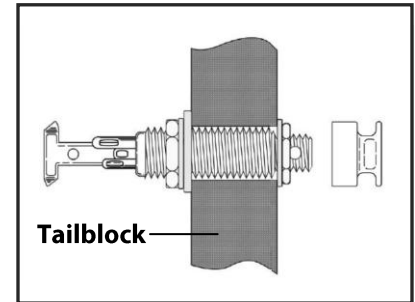

Fig. 2

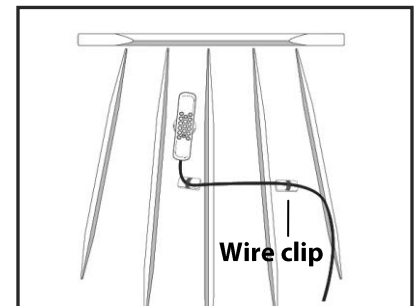

Fig. 3

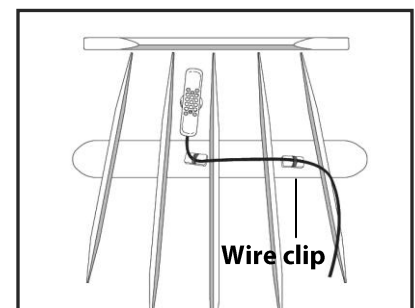

Fig. 4

